



SPE 152188

## BC-10: The First Successful Replacements of Caisson ESPs in Deepwater Brazil

David Harris, SPE, Baker Hughes; Wouter Bode, Shell Brazil E&P; Ignacio Martinez, Baker Hughes; Robert Rivera, Shell International E&P Inc; Natalya Hines Shell International E&P Inc.

Copyright 2012, Society of Petroleum Engineers

This paper was prepared for presentation at the Latin American and Caribbean Petroleum Engineering Conference, 16-18 April 2012.

This paper was selected for presentation by an SPE program committee following review of information contained in an abstract submitted by the author(s). Contents of the paper have not been reviewed by the Society of Petroleum Engineers and are subject to correction by the author(s). The material does not necessarily reflect any position of the Society of Petroleum Engineers, its officers, or members. Electronic reproduction, distribution, or storage of any part of this paper without the written consent of the Society of Petroleum Engineers is prohibited. Permission to reproduce in print is restricted to an abstract of not more than 300 words; illustrations may not be copied. The abstract must contain conspicuous acknowledgment of SPE copyright.

### Abstract

The Parque das Conchas development is located in the BC-10 block 75 miles southeast of Vitoria in the Campos Basin, offshore Brazil. Shell is the operator with a 50% equity share, with joint venture partners Petrobras (35%) and ONGC (15%). The current development consists of three hydrostatically pressurized medium to heavy oil reservoirs (Abalone, Ostra and Argonauta B West) in water depths ranging from 5430 ft to 6310 ft (1655 m to 1923 m). One of the key enabling technologies at the heart of the subsea system infrastructure is the mudline boosting system consisting of Modulo de Bombeio or Pumping Unit (MOBO) caisson ESPs installed inside Artificial Lift Manifolds (ALMs)<sup>1)</sup>. Oil from the individual subsea wells flows into the MOBO caisson ESPs and from there the ESPs pump the oil up to the floating production, storage and offloading (FPSO) vessel. The ALMs are located approximately 5½ miles (8.85 km) from the FPSO (see Figs. 1 and 2).

This paper will describe how the design for these special longlife ESPs was developed, how a stack-up test was performed on land in the US, and how the pumps were deployed in the field. In the second part, the first operations for pulling two of the ESPs are described. The whole assembly consisting of the MOBO, 32-in. caisson and ESP completion was lifted in open water to the rig with a total assembled weight of 169 tons (171.7 metric tons).

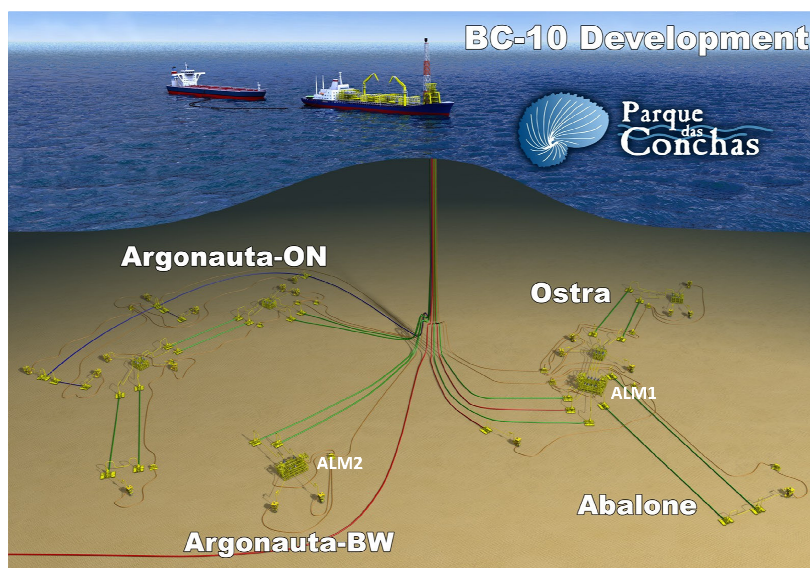

Figure 1: BC-10 Field layout overview.

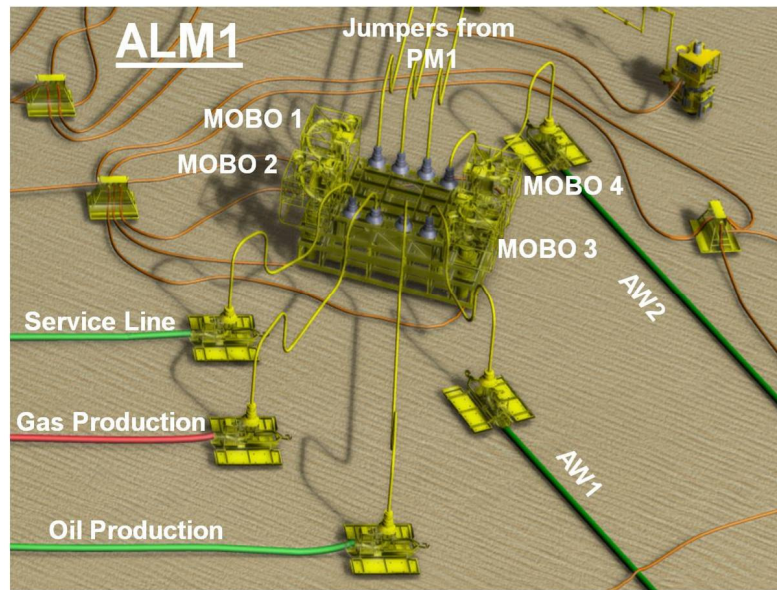

Figure 2: ALM and subsea wells.

### Introduction

Phase 1 of the Parque das Conchas development, located in Block BC-10 offshore Brazil encompasses three separate fields: Ostra, Abalone, and Argonauta.

Two of the fields, Ostra and Argonauta, are equipped with MOBO caisson ESP systems located inside an ALM at the seabed. Several production wells can feed one MOBO caisson ESP; however, due to different operating conditions and philosophies, both fields have different configurations.

The Ostra field is composed of two connected production manifolds that bring the production from several wells to the ALM#1. The ALM#1 is approximately 5½ miles (8.85 km) from the FPSO and comprises four caisson ESP systems.

Each ESP completion is enclosed in a MOBO and 32-in. caisson and there is a gas line that connects the four caissons to the FPSO. The gas is separated from the liquids and vented through the gas line to the FPSO. This configuration is called a “separated caisson ESP system.” It allows the liquids to fall to the bottom of the caisson, where they are pumped through a flowline by the ESP equipment to the FPSO. The ESP operates as a fluid-level-control device in the caisson. The pressure on the gas line controls the intake pressure on the ESP equipment and that pressure can be adjusted from the FPSO (see Fig. 3).

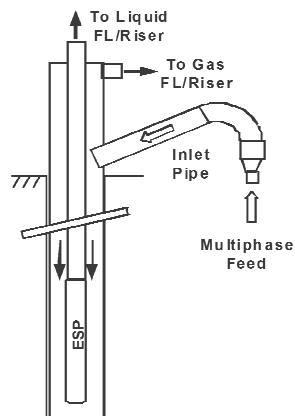

Figure 3: Separated caisson ESP system.

Production from Abalone, the third field in the BC-10 complex, is co-mingled with the Ostra field. Abalone has a low flow rate and high gas-to-oil ratio; the high gas rate allows pressure to be kept on the gas line.

In the second field, Argonauta, the MOBO caisson ESPs are also fed with several production wells, but there is no gas separation. It is the pulling of two MOBO caisson ESP systems in this field that is described in the latter part of this paper.

The non separated MOBO caisson ESP systems are designed to handle more than 40% gas entrained in the liquids. In this case, the intake pressure is controlled by the ESP. Argonauta, with 17 API oil and 40% free gas, is heavier than Ostra, where the oil is 28 API but the free gas is only 10%, which also affects the operational procedures.

The objective was to supply enhanced run life ESP systems based on proven technology with high power and high volume that are able to meet both scenarios where rapid gas decompression and temperature cycles occur, that are also compatible with the subsea infrastructure and Shell's operational philosophy.

Critical to the successful overcoming of the challenges was the fact that the ESPs were planned as an integral component of the entire hardware configuration. This differed from the approach where the ESP is considered a separate item instead of being pre-planned as part of the final configuration.

This project presented unique challenges and demanded innovative approaches to meet Shell's needs. Although the service company has a demonstrated track record in subsea applications, the complexity of this subsea infrastructure and associated procedures for BC-10 called upon many of the company's resources. Many hours were dedicated to workshops, internal meetings, and meetings with experts from Shell.

Figs. 4 and 5 provide an overview sketch of the ESP assembly.

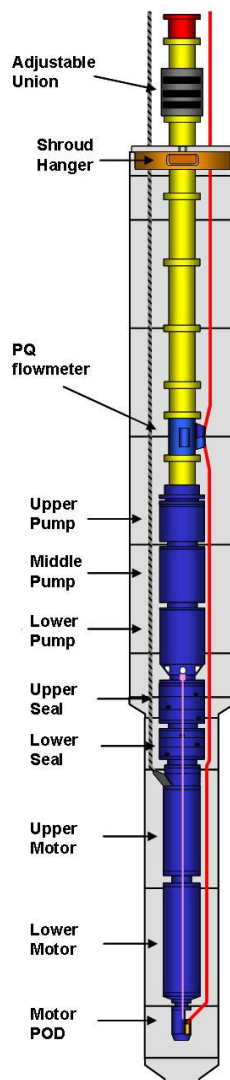

Figure 4: ESP schematic.

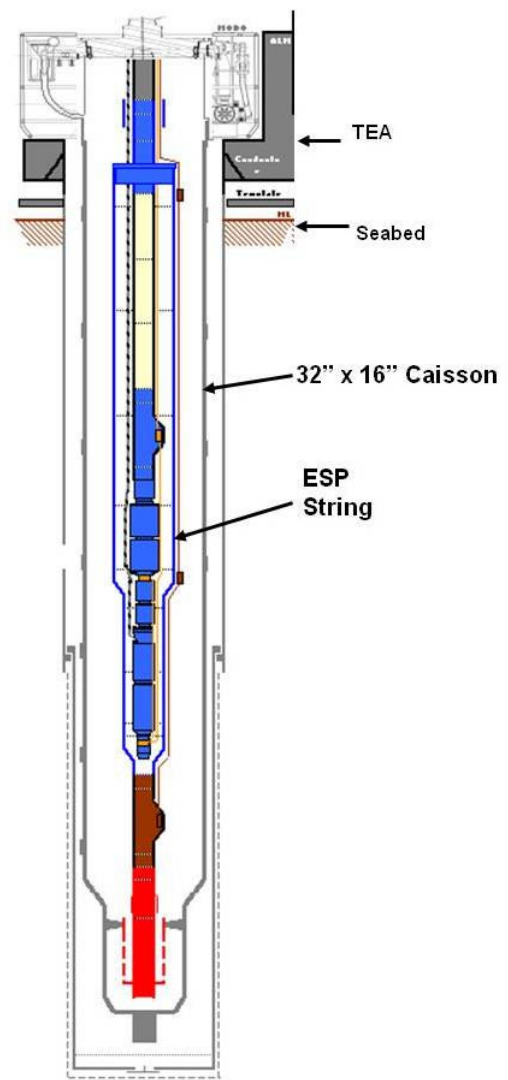

Figure 5: Caisson with MOBO.

Testing of new solutions was required, as the hardware and new procedures were developed to operate and control the ESP equipment. A full stack-up test was performed at a land test rig in Louisiana to ensure that all the components worked and to determine the best field practices. Many of the hardware solutions found in the BC-10 ESP equipment are unique.

Specifically, the motor used for the ESPs in the BC-10 development was designed and manufactured with new high-end technology seals. The “Vanguard” design has been proven to enhance reliability when compared with standard motor construction. The extreme performance motor with the incorporated Vanguard technology is a precision design, manufactured to the highest industry standards. The motors are assembled in a specially designed facility under the close scrutiny of the company’s design engineers. See Fig. 6 for an illustration of the unique seals.



**Figure 6: Bearing and seals for ESP.**

The main hardware improvements were made to the seal section and were required because of the expected rapid decompression during some transient periods of operation. Solutions were developed to hold up to 1,000 psi (14.5 bar) per minute of gas decompression from 3,000 psi (43.48 bar) to 1,000 psi (14.5 bar) and 350 psi (5.07 bar) per minute from 1,000 psi (14.5 bar) to 300 psi (4.35 bar).

Because rapid decompression is detrimental to all elastomers, it necessitated evaluation of the composition and resulted in a change to the metal configurations. Components such as O-rings on the motor and pump and the power cable were evaluated and then upgraded.

The BC-10 operational procedures are unique and involve a new philosophy of how to operate ESP equipment. Commissioning of the system and startup has gone exactly as planned and the systems have been in continual operation. To date there is no subsea boosting system that has the high volume and high boosting pressure capabilities of these ESP systems. These are considered the most cost effective solutions to the type of operations present in the BC-10 development.

Early research and development also improved the quality of the outcome of the project. Often this is influenced by the process and relationship between the operator and the contractor. In many cases, the operator focuses on the ESP hardware only, neglecting the importance of the process in the conceptual phase of the project. The successful outcome of the BC-10 development can be attributed to the collaboration between operator and contractor in solving the unique challenges that the field development posed.

Research and development into installation testing was carried out at the company’s facilities in Oklahoma, USA. The most important was the development of a new high-viscosity loop to determine pump operating performance and motor temperature profiles in high-viscosity scenarios.

This was the first time that high-volume pumps of 10,000 bopd to 40,000 bopd were tested under those conditions. The results were very successful, demonstrating that high-volume ESP pumps can be much more efficient than had previously been expected.

#### **Operation of the ESPs in the field and the Pulling of the first two ESPs**

The pumps were delivered from the manufacturing facility in Oklahoma to the Artificial Lift group’s new purpose-built facilities in Macae, Brazil, where final assembly and testing of the ESPs was performed before the pumps were sent offshore.

Beginning in 2009, the first MOBO caisson ESP systems were installed in the BC-10 field from the Transocean rig Arctic 1.

Prior to that, a spacer template and 48-in. (122-cm) conductors had to be installed, making use of a subsea hydraulic hammer (Noort et al., 2009). The rig later drilled to approx 360 ft (110 m) below mudline and 42-in. (106.7-cm) liners were installed. The next step was to install the ALM manifold. The rig then returned to install the MOBO caisson ESP system (Olijnik et al., 2009) (see Fig.7).

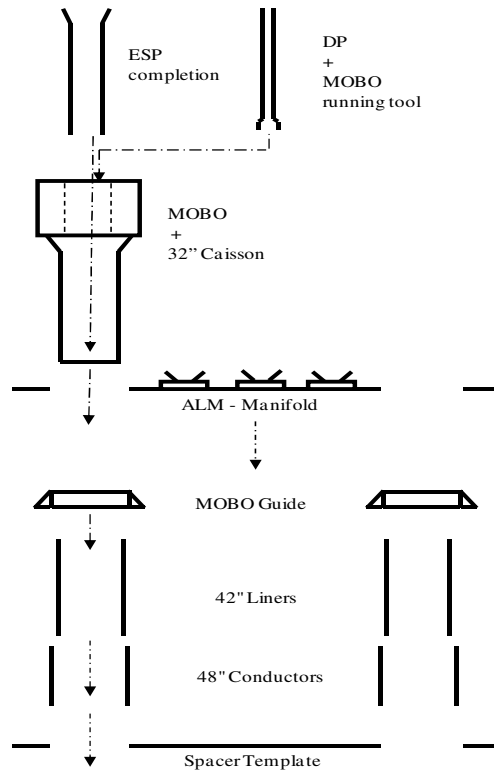

Figure 7: Overall installation sequence subsea boosting system.

The handling and assembly of the 32-in. caisson and MOBO necessitated special handling equipment such as the moonpool launching bridge and 32-in. special size elevators to handle the 32-in. caisson (see Figs. 8, 9, and 10).

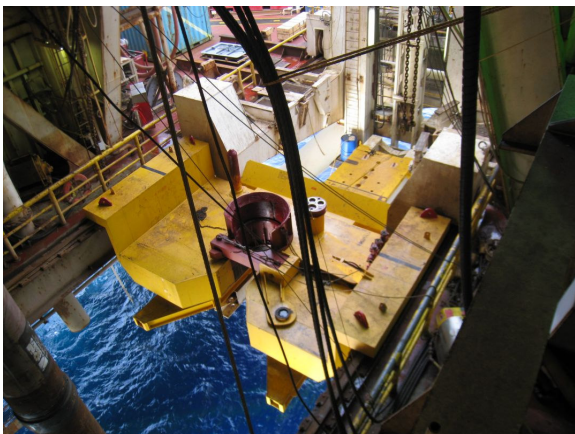
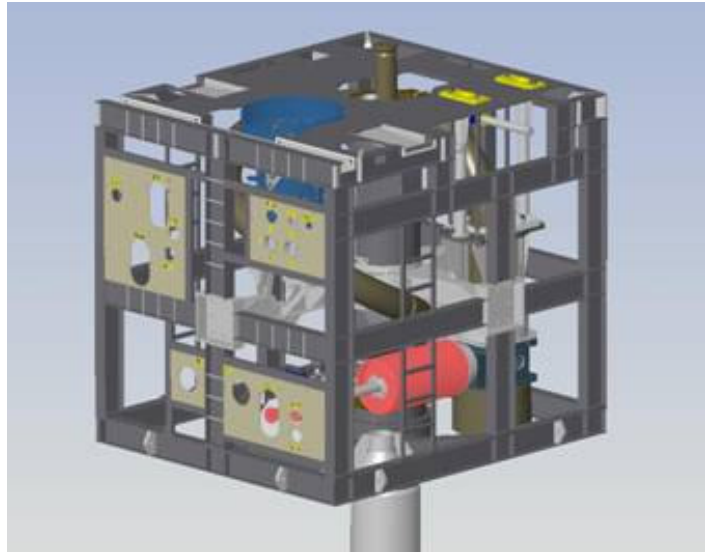

Figure 8: Moonpool launching bridge.



Figure 9: 32-in. caisson being run with 32-in. elevators.

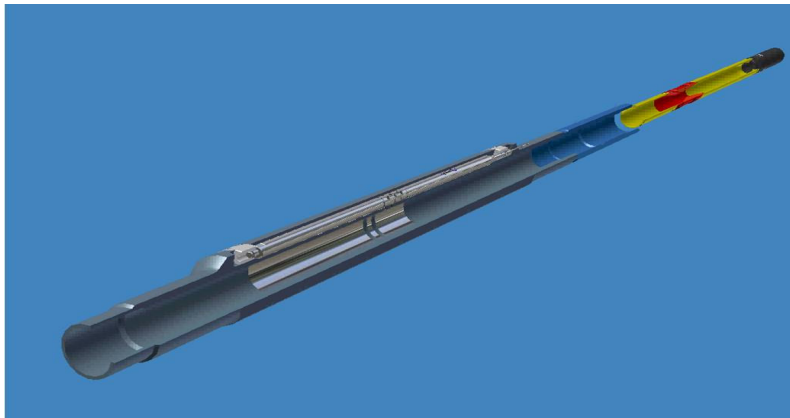

**Figure 10: MOBO caisson ESP system.**

Special care had to be taken when running the assembly with the ESP cable and other control lines to ensure that they were not compromised in any way.

Another important part of the ESP assemblies is the high-accuracy flowmeter provided by Baker Hughes' Intelligent Production Systems group. Using a Venturi sleeve and high-accuracy quartz gauges, this flowmeter provides the highest available measurement accuracy and has been approved for similar ESP installations in the Gulf of Mexico.

The flowmeter has been used in the BC-10 field for monitoring purposes as well as to determine the actual flow rate handled by the ESP/caisson system. Knowing the flow rate and the differential pressures of the pump gives guidance on the health of the pump and is used to help optimize the system (see Fig. 11).



**Figure 11: Flowmeter.**

After 235 days in operation, it was found necessary to pull the two MOBO caisson ESP systems in the Argonauta or B-West field to replace the ESP completions. Careful planning and integration was carried out between all the service companies and Shell, because this pulling operation had not been carried out anywhere in the world in such deep water.

The workover operations were carried out from the rig Noble Clyde Boudreaux in May 2011. The launching bridge, now modified for the new rig, held the weight of the caisson and the whole assembly.

After subsea flushing and venting of the system to the FPSO, the system was recovered, vented of remaining pressure ( $\pm 140$  psi/9.6 bar), displaced to nitrogen to remove remaining oily water and refilled with clean brine (see Figs. 12 and 13).

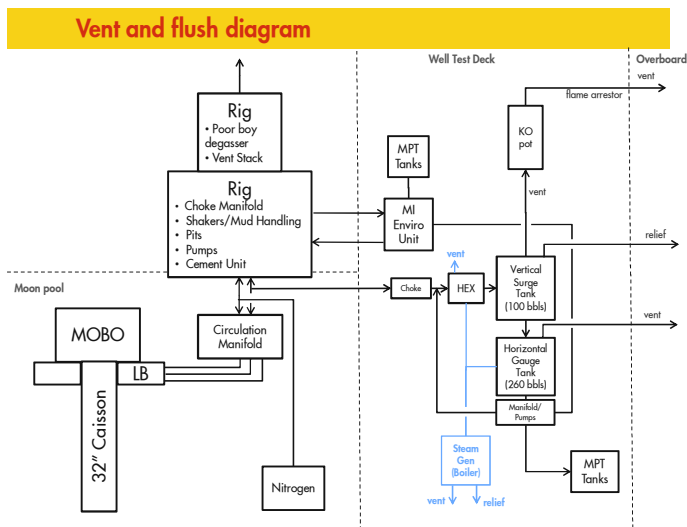

Figure 12: Vent and flush system.

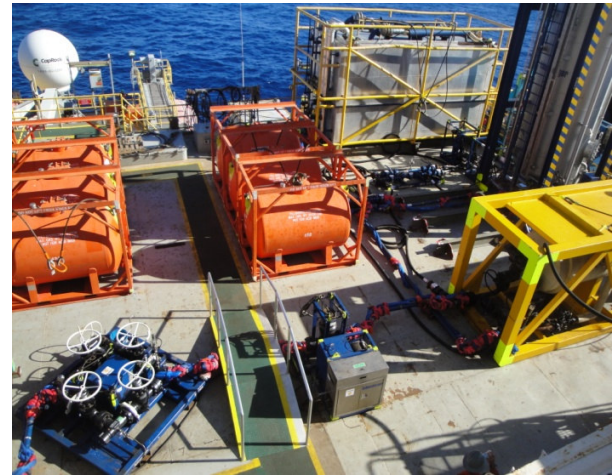

Figure 13: Vent and flush spread on well test deck.

Then the ESP completion was recovered consisting of the ESP itself, a shroud comprising joints of 13 $\frac{3}{8}$ -in. and 10 $\frac{3}{4}$ -in. casing and joints of 5 $\frac{1}{2}$ -in. tubing with premium connections. The Tubular Services group used special 7 $\frac{7}{8}$ -in. tongs for the tubing and 14-in. high-torque tongs for the casing.

Other equipment that was used for both the pulling of the assemblies and the re-running included the Salvo torque turn systems, elevators, slips and a special 25-ton (22.7-metric ton) single-joint compensator.

The single-joint compensator was used to be able to pick up the ESP hanger and assembly and hold it while the connections were broken out. This avoided jump-out of the pins from the boxes of the connections and any subsequent damage to the threads. The aim was to be able to re-run as many components of the ESP assembly as was possible.

When the ESP was recovered to the rig floor, the power cable and the control lines were severed. After the ESPs had been extracted from the caissons a check trip was made to confirm the hold up depth and no debris in the bottom of the 32-in. caisson. The separate sections of the ESP were laid out on the rig floor and subsequently the new ESP was picked up and run back inside the caisson. When the whole MOBO caisson ESP system was re-assembled and pressure tested, it was run back to the seabed level and landed. In both cases, all went as planned and subsequently the wells and ALMs were put back on production.

The intervention was performed in very good time with no nonproductive time, saving three days from the forecast time for the operations for the two ESPs. See photos from the pulling and re-running operations in Appendix A. The failed pumps were returned to shore and forensic investigations were carried out. The lessons learned will be used to make further improvements to these exceptional longlife pumps.

## Conclusions

The successful outcome of both the installation and pulling and re-running operations showed that it is possible to use ESP mudline boosting systems successfully in water depths of 5,500 ft (1676 m) and enable lift of medium to heavy oil at economic rates.

There is no doubt that the hard work put into the design, testing, installation, pulling, and re-running made these ESP operations successful. Much of this success was due to the careful planning that was carried out and the excellent co-operation between Shell, Baker Hughes, FMC and several other companies, including the rig contractor. It should be noted that the other ESPs in the field have been running without interruption for more than 600 days, as of the time of writing.

Looking ahead, it can be safely forecast that, in the future, there will be many more successful uses of ESPs in deepwater, not only with the caissons, as in this case, but also where the ESPs are placed directly in the wells.

## Acknowledgments

The authors would like to recognize Shell, Baker Hughes, Petrobras and ONGC for permission to publish this paper and wish to thank many people involved at Baker Hughes, FMC, Shell and other service companies for making the design, installation, operation and workovers a great success.

**Appendix A – Pulling and Re-Running Operation**



**Chromemaster tong breaking out ESP.**

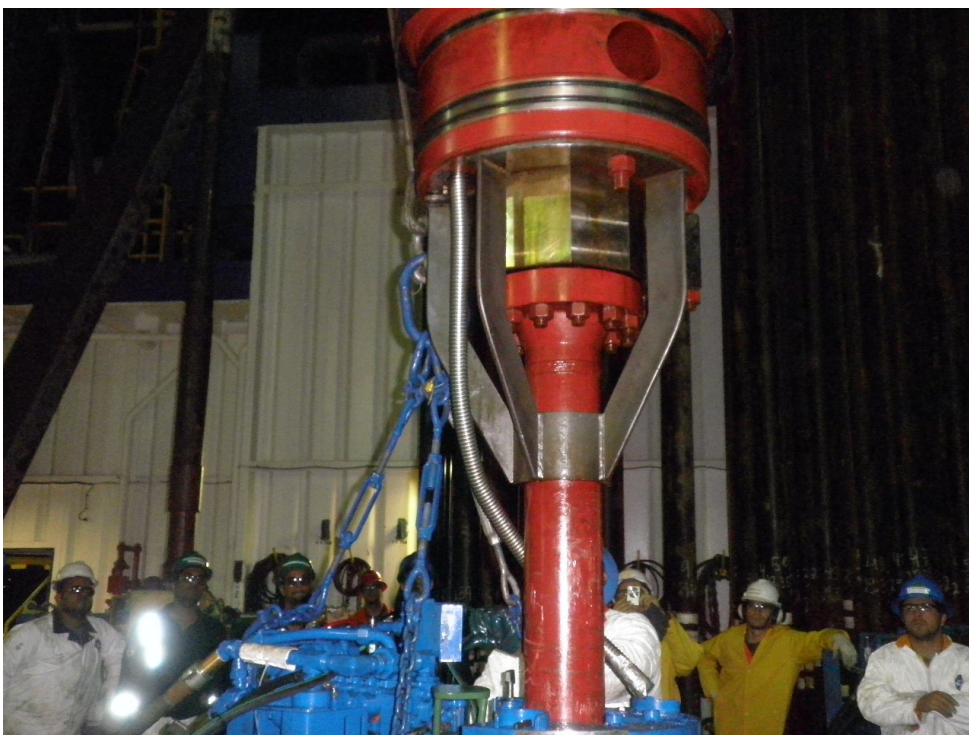

**ESP hanger with tong below.**





**Pulling caisson BC-10.**



**Tong and backup breaking connection.**



25-ton single-joint compensator.



Tong crew and ESP hanger.



Spooler for ESP cable.

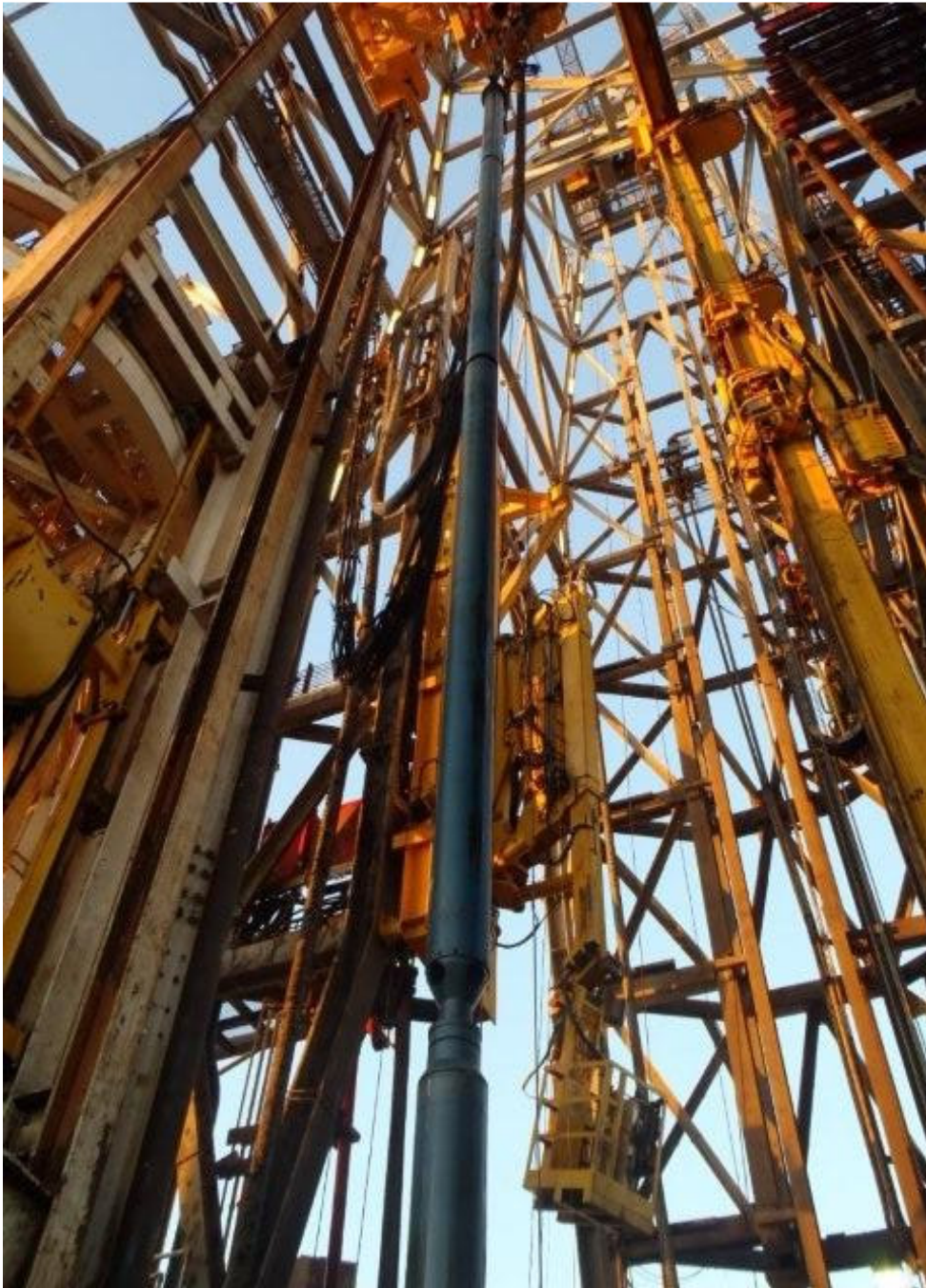

**ESP being re-run with seal section and pumps.**



Installing the vibration clamp at the ESP pump intake.

## References

- L. Olijnik, D. La Caze: Parque das Conchas – BC-10 – Subsea Hardware Systems: Selection, Challenges and Lessons Learned, paper OTC 20649, 2010 Offshore Technology Conference, Houston, Texas, U.S.A., 3 – 6 May 2010.
- K. H. Stingl, A. Paardekam: Parque das Conchas – BC-10 – An Ultra-Deepwater Heavy Oil Development Offshore Brazil, paper OTC 20537, 2010 Offshore Technology Conference, Houston, Texas, U.S.A., 3 – 6 May 2010.
- R. van Noort, R. Murray, J. Wise: Conductor Pre-Installation Deepwater Brazil, paper OTC 20005, 2009 Offshore Technology Conference, Houston, Texas, 4 - 7 May 2009.